



griffin & ray

# LED Lighting

## Highbay Lights



## Applications

LED High Bay Lighting is an ideal solution for energy efficient lighting retrofits in Warehouse, Retail, Commercial, Exhibition Halls, Supermarkets, Food Storage / Processing, Hospitals, Manufacturing and Industrial facilities.

The lamp lasts longer – in fact, up to 50,000 hours and is best suited for applications where lighting is difficult or expensive to replace due to the accessibility of the lights. Generates 50 % lesser heat compared to traditional lamps with an additional saving on HVAC costs.

100-250  
W

# LED

# Highbay Light



## Features

- ▶ Latest LED Technology.
- ▶ Built-in Reflectors
- ▶ No Glare and Flickering.
- ▶ No Halo , No Multiple Shadow Effect.
- ▶ Long Life Time 60000 to 100000 Hours.
- ▶ Cool Beam , No UV or Thermal Radiation.
- ▶ Eco-Friendly Light Source.
- ▶ Reduces Carbon Foot Print.

Product Code	Voltage (V)	Watts (W)	Lumens (Lm)	CCT	Power Factor
GRLHB100WW	230V AC	100	6000-6600	2700K-3500K	>0.98
GRLHB100CW	230V AC	100	7000-7200	5000K-6500K	>0.98
GRLHB120WW	230V AC	120	7200-7500	2700K-3500K	>0.98
GRLHB120CW	230V AC	120	8000-8500	5000K-6500K	>0.98
GRLHB150WW	230V AC	150	10000-10500	2700K-3500K	>0.98
GRLHB150CW	230V AC	150	11000-12000	5000K-6500K	>0.98
GRLHB200WW	230V AC	200	13000-14000	2700K-3500K	>0.98
GRLHB200CW	230V AC	200	15000-16000	5000K-6500K	>0.98
GRLH250WW	230V AC	250	17000-17500	2700K-3500K	>0.98
GRLH250CW	230V AC	250	19000-20000	5000K-6500K	>0.98

## Dimension

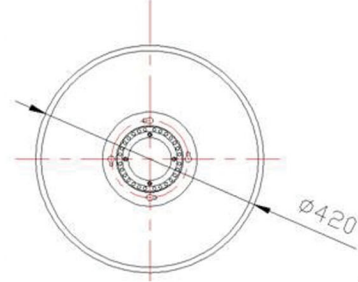
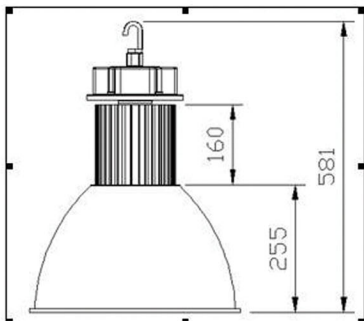

[www.griffin-ray.com](http://www.griffin-ray.com)

## Griffin & Ray Inc.

5201,  
Great America Park way,  
Suite 256  
Santa Clara  
California  
USA.

☎ +1 408 8459411

☎ +1 408 7776375

🌐 [www.griffin-ray.com](http://www.griffin-ray.com)

✉ [info@griffin-ray.com](mailto:info@griffin-ray.com)



griffin & ray